

# SeaPaCS

## Participatory Citizen Science against Marine Pollution

(Italian: Cittadin\*-Scienziat\* contro la Plastica in Mare)

*SeaPaCS proposes a participatory citizen science (CS) project led by social and natural scientists that mobilises volunteers in data collection, elaboration and sharing on the biological consequences of marine plastic pollution (via in-situ samples collection for plastisphere DNA analysis, underwater video documentation of new ecological niches, plankton evaluation), and in drafting a plan for sustainability-oriented practices based on interviews with fishermen and sailors, in the coastal city of Anzio (Italy) on the Mediterranean Sea.*

### What is SeaPaCS

[SeaPaCS](#) project, supported by the European funds of the [IMPETUS4CS](#) project is coordinated by Chiara Certomà ([DIGGEO@ESOMAS](#) laboratory, University of Turin) and co-coordinated by Federico Fornaro ([Italian Naval League](#) Anzio) and Luisa Galgani (Marine Biochemistry Division of [GEOMAR Helmholtz Centre for Ocean Research](#) Kiel).

SeaPaCS is intended to raise awareness about the consequences of marine plastic pollution on local biodiversity and to trigger transformative local action for sustainability-oriented behaviours in the coastal small city of Anzio (Rome). It answers two complementary **research questions**:

- What microbes are present in the Mediterranean plastisphere (i.e. the living microbial community on plastics and microplastics in marine environments) and how are they affecting the biodiversity of the Mediterranean ecosystem?
- How can the experience of sea workers and amateurs help decrease plastic debris and promote sustainable behaviours?

SeaPaCS combines natural and social science research and **engages multiple citizen groups** (migrant fishermen cooperatives, students, associations, sailors and divers, scientists, video makers and photographers) in “collaboratorium” meetings, training sessions and co-production of tools for collective sea-going expeditions in the coastal waters (for plastic samples collection, microbial life analysis, interviews and video-documentation of new biological formation and fishing plastic practices), organisation of outreach activities (e.g. video and photo expositions, media coverage, redaction of follow-up plan).

SeaPaCS is included in the [Public Engagement projects at ESOMAS Dep.](#)– University of Turin, [institutional page available here.](#)

SeaPaCS’s topic and aims situate within the IMPETUS’ **Healthy Planet** challenge (with specific reference to water and biodiversity subtopics). It connects with the **EU Green Deal**’s goal of “Protecting our Environment”, notably by maintaining clean water and biodiversity while ensuring no person or place is left behind. It also contributes to **U.N. SDG 6** (indicator 6.3) on water-related ecosystems and **14** (ind.14.1 and 14.2) on the consequences of marine plastic pollution towards sustainable use of the ocean; and refers to **SDG 15** (ind.15.8) on biodiversity loss.

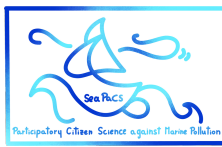

SeaPaCS focuses on the **Mediterranean Sea**, a hotspot for unique habitats that hosts 32% of all European-threatened marine ecosystems, and acts as a plastic accumulation zone. SeaPaCS covers the coastal waters (12 miles from shore) of the small village of **Anzio** (60 km south of **Rome**, Latium region, 50.000 inhab.) whose local economy is highly dependent on the sea (fishing, commercial boating, and tourism).

## Activities

*Photo exhibition on New Hybrid Ecologies of the Mediterranean Sea* (<https://crowdusg.net/2023/05/23/photo-exhibition-on-new-hybrid-ecologies-of-the-mediterranean-sea/>)

“Explorations in the Plasticsphere” is the title of the new photo exhibition promoted in the series of public engagement activities at the Department of Economics, Social Studies, Applied Mathematics and Statistics (ESOMAS) – University of Turin. Organised by dr. Chiara Certomà’s research team [DIGGEO@ESOMAS](mailto:DIGGEO@ESOMAS), the exhibition proposes an unconventional

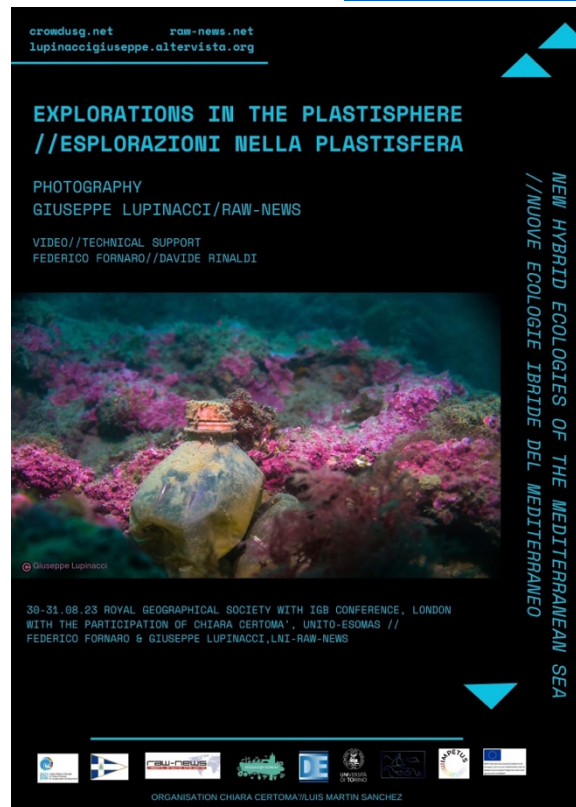

perspective on one of the most cogent issues of our time, i.e. the marine plastic pollution, by visually investigating the new hybrid ecologies emerging on the plasticsphere, a collective of plastic-colonising organisms (biofilms, organisms that stick to each other and other things), including bacteria and fungi and complex ecosystems, that have evolved to live on microplastics, and various anthropic debris in marine environments (including relicts, ghost nets, infrastructures, and polluted sites...). [DIGGEO@ESOMAS](mailto:DIGGEO@ESOMAS) commissioned and supported the maritime and underwater photography expedition.

Water photographer Giuseppe Lupinacci (Raw News), with the technical support of independent video-maker Federico Fornaro, director of the Italian Naval League- Anzio and of [Raw-News](http://Raw-News) media agency, and Davide Rinaldi, director of the diving centre “Capo D’Anzio”, documented in 16 amazing shoots the emerging ecologies and recombinant biologies of the plasticsphere in the Mediterranean Sea, a semi-enclosed basin surrounded by plastic sources with plastic concentrations and comparable to the world’s largest accumulation zones.

The visual documentation feeds critical geographers’ emergent work on how new hybrid assemblages are reshaping and re-signifying the ecological life-supporting systems by building upon the material-semiotic of more-than-human assemblages.

The shots will be exhibited at national and international venues, in combination with the presentation of Certomà’s work conducted at the University of Turin (see for instance [plastisphere and participation](#)).

The exposition has been inaugurated during the “[CommonsHood in the Garden meet the local associations](#)” (funded by CRT) at the Orto della SME on 25.05. 2023.

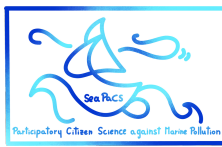

The exhibition will then travel the following scientific events:

- 05.06.2023, ASLO Aquatic Science Meeting, Palma de Mallorca, in concomitance with of the session Exploring the Emotional Connection Between Society and the Ocean (EP004) organized by Chiara Certomà, Luisa Galgani, Allison Fong, Ngozi Oguguah and Ana Fernández Carrera. In describing the undertaken documentation work Certoma' is giving a tutorial speech titled “Exploring participatory knowledge creation practices for tightening society’s attachment to the Ocean”, while Cristina Romera Castillo (Instituto de Ciencias del Mar-CSIC) will deliver the invited talk “How to get people unfamiliar with the ocean to care about its conservation”
- 07.06.2023 International Geographical Union Conference, University Milan Bicocca, the exposition could be accessed in the main conference hall, and referred to by the sessions “Territorialising the High Sea. Socio-cultural mapping the interaction between humans and the Ocean” (#20) organised by Chiara Certoma' and Luisa Galgani with the participation of Federico Fornaro on “insight from the Oceanic Sailing”, and the presentation of the work titled ““Staying with the problem” in the Ocean.
- On the plastisphere as the hybrid ecological formation of the Chthulucene” (in session 22).
- 31.08.2023 Royal Geographical Society with IGB Conference, London, the pictures will be displayed during the session “Blue Hauntologies and Spectral Seas”, organized by Rapti Siriwardane-de Zoysa and Iqbal Hafizhul Lisan, where Certoma and is presenting her work.
- From 15.06 to 15.12.2023 the exposition will be located at the Italian Naval League in Anzio – Rome, where the participatory project [SeaPaCS “Participatory Citizen Science against marine pollution”](#), under negotiation for the funding by EU project IMPETUS, is run by Certomà, Galgani and Fornaro.
- From 15.01.2024 onward the “Explorations in the Plastisphere” exposition will be stably located at the ESOMAS Department, University of Turin.

**Cittadin\*-Scienziat\*  
contro la Plastica  
in Mare**

**Anzio  
Plastic  
Free!**

**1 luglio 2023  
ore 17:30**

**APERITIVO  
SCIENTIFICO**

**Lega Navale  
Italiana di Anzio  
Riviera Zanardelli 22  
Info: 338-385-8424**

**Ingresso libero  
e gratuito**

WhatsApp: +39-338-385-8424 - Telegram: t.me/seapacsanzio

con il Patrocinio  
del Comune di Anzio

*Scientific Aperitif at the seaside. First Collaboratorium of SeaPaCS*

[\(https://crowdusg.net/2023/06/18/scientific-aperitive-at-the-seaside-first-collaboratorium-seapacs/\)](https://crowdusg.net/2023/06/18/scientific-aperitive-at-the-seaside-first-collaboratorium-seapacs/)

On the 1<sup>st</sup> of June, 5.30 pm, we are kicking off the [SeaPaCS](#) project at the Italian Naval League in Anzio (Riviera Zanardelli 38). Citizens are all invited to join the SeaPaCS team for a thrilling and tasty initiative of presentation and networking.

During the Scientific Aperitif, which represents the first of a series of events scheduled during the SeaPaCS project, information will be provided, through multimedia materials, on the most recent research relating to plastic pollution in the sea, and on the experience of various participants (fishermen, students, sports and environmental associations, video makers and photographers, local administrations and institutions).

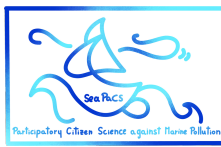

We will produce self-produced monitoring and sampling tools, show the video “In search of plastic. Sampling plastic at sea” and enjoy the photographic exhibitions entitled “Anzio under the sea. Resistant Ecologies of the Mediterranean” and “[Explorations of the Plastisphere. New hybrid ecologies of the Mediterranean](https://crowdusg.net/2023/06/19/resistant-ecologies-of-the-mediterranean-sea_seapacs/)”. Participation is free.

The provisional schedule of the aperitif includes:

Federico Fornaro and local representatives: Welcome greetings

Chiara Certomà: presentation of SeaPaCS project

Luisa Galgani: Plastic and microplastic in the sea: where are we now?

Video “In search of plastic. Sampling plastic at sea”

Participants’ interventions on their encounters with plastic at sea and initiatives

Aperitif, photo exhibition “Anzio at the bottom of the sea. Resistant Ecologies of the Mediterranean” and “[Explorations of the Plastisphere. New hybrid ecologies of the Mediterranean](https://crowdusg.net/2023/06/19/resistant-ecologies-of-the-mediterranean-sea_seapacs/)” and creation of baby legs.

*Resistant Ecologies of the Mediterranean Sea* ([https://crowdusg.net/2023/06/19/resistant-ecologies-of-the-mediterranean-sea\\_seapacs/](https://crowdusg.net/2023/06/19/resistant-ecologies-of-the-mediterranean-sea_seapacs/))



On the occasion of the SeaPaCS Scientific Aperitive – First Collaboratorium on the 1<sup>st</sup> of June, 5.30 pm, at the Italian Naval League in Anzio (Riviera Zanardelli 38), the SeaPaCS team is happy to present a new wonderful photo exhibition.

In following with the research line of Chiara Certomà’s research team [DIGGEO@ESOMAS](mailto:DIGGEO@ESOMAS), promoted as public engagement activities by the Department ESOMAS – University of Turin, and supporting the SeaPaCS project, the new visual production expands the investigative activities about the current transformation of the marine environment and its relationships with society.

Raw News agency (photography Giuseppe Lupinacci, video-making Federico Fornaro) with the support of “Capo D’Anzio Diving Center” (Davide Rinaldi) is presenting a new photographic exhibition titled “Anzio under the sea. Resistant Ecologies of the Mediterranean Sea”, presenting in 10 shots

the resilient biological organisms that are resisting the changed oceanic conditions, due to multiple anthropic-generated problems (increase in sea-surface temperature, tropicalization, ocean acidification, loss of oxygen, plastic pollution to name a few). The exhibition will be accessible for the whole duration of SeaPaCS project at the Italian Naval League Anzio.



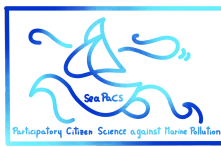

*In Search of Plastic* ([https://crowdusg.net/2023/07/01/in-search-of-plastic\\_seapacs-first-video/](https://crowdusg.net/2023/07/01/in-search-of-plastic_seapacs-first-video/))



During the [SeaPaCS Scientific Aperitif – First Collaboratorium](#) on the 1<sup>st</sup> of June, 5.30 pm, at the Italian Naval League in Anzio (Riviera Zanardelli 38), the [SeaPaCS](#) team is happy to present a new fantastic photo exhibition.

Supported by the public engagement activities funds by the [DIGGEO@ESOMAS](#), Department ESOMAS – University of Turin and the SeaPaCS project (funded by [IMPETUS project](#) – funded by the European Union), the video tells a compelling story about

the [explorations of the plastisphere](#) and [its visual documentation](#).

Produced by Raw News agency (filmed by Giuseppe Lupinacci, directed by Federico Fornaro) with the support of “Capo D’Anzio Diving Center” (Davide Rinaldi) the video is available at <https://youtu.be/G8qLMumEQ7Q>.

*Kick-off meeting of SeaPaCS project* (<https://crowdusg.net/2023/07/03/seapacs-first-collaboratorium/>)



At the Anzio (Rome) headquarters of the Italian Naval League (Lega Navale Italiana – LNI), the SeaPaCS project officially started with the first “Scientific Aperitif – First Collaboratorium”. In the same venue, also, the photographic exhibition “Anzio in fondo al mare” (Anzio at the bottom of the sea) by Giuseppe Lupinacci was inaugurated.

The SeaPaCS project, supported by European funds of the IMPETUS project, has been created to sensibilise the citizens about the consequences of plastic pollution on local biodiversity and to trigger transformative actions towards sustainability in the coastal city of Anzio.

About 60 people participated as representatives of local institutions, environmental, cultural, and sport associations (Circolo Velico L’Atollo – Lavinio and Circolo Velico Campeggiatori

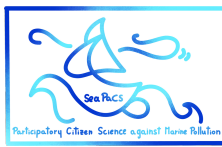

Romani – Lido dei Pini), sailors, fishermen of cooperatives Fanciulla d’Anzio and Concordia, and representatives of the association for the plastic recovery at sea Innocenziana.

After the formal greetings and introduction by Federico Fornaro for the Italian Naval League, researcher Chiara Certomà (Social Geography of DIGGEO@ESOMAS of the University of Turin), presented to the participants the aim of the project. Afterwards, researcher Luisa Galgani (GEOMAR Helmholtz Center for Ocean Research of Kiel, Germany) presented the plastic and microplastic situation and their impacts in the seas and oceans, with particular reference to the Mediterranean Sea.

The videoclip “In cerca della plastica” (In search for plastic), about the microplastic sampling techniques on board of a sailing boat, shot and edited by Federico Fornaro for RawNews, has been projected.

Finally, the representatives of the institutions and associations took the floor:

- Lorenzo Colantuono, fisherman and general secretary of the Association Innocenziana;
- lawyer Andrea Petraghani Ciancarelli, of the law firm Petraghani Ciancarelli, that is specialized in international and marine law;
- Marshal Carmelo Foti of the Anzio Coast Guard;
- Giulia Bortolotti for SeaShepherd;
- Biologist Martina Gaglioffi, UN Unesco Ocean Decade consultant;
- UPA coordinator Capt. Gilberto Zampighi;
- Diego Capobianco, director of the Circolo Velico L’Atollo – Lavinio;
- Teachers of the schools Loretta Paloma and Valentina Schinzari.

There was great interest for the photographic exhibitions at the headquarters of the Italian Naval League, particularly for the one just inaugurated (“Anzio in fondo al mare”) and for the videoclip “In cerca della plastica”.

During the aperitive, then, the participants built the “baby-legs trawls” (little sampling nets for microplastics made out of baby collants and many suggestions for operational proposals came from the citizens.

Illustration by [Veronica Vitale](#).

A short video recording of the event has been produced by Saverio Lalli of association [Terra nel Cuore](#): [https://youtu.be/PYJ8yicR\\_Ys?si=F5qjUAVSj5mNS4eT](https://youtu.be/PYJ8yicR_Ys?si=F5qjUAVSj5mNS4eT).

*Fishing for Plastic (<https://crowdusg.net/2023/07/08/fishing-for-plastic/>)*

On the 12<sup>th</sup> of July, researchers of the european project SeaPaCS – Citizen Scientists against Marine Pollution (from the University of Turin, ESOMAS Dept., Italian Naval League and GEOMAR Helmholtz Center for Ocean Research Kiel in Germany) and the film-maker crew of the independent video-documentary society “Raw-News”, are leaving from the port of Anzio on the fishing boat Paola Madre owned by Angelo Grillo together with the fishermen crew, for a marine plastic search and recover trip.

SeaPaCS team is conducting on board interviews during the usual fishing activity and documenting the work performed by the fishermen. The “experts of the sea” are fundamental witnesses on the marine plastic pollution problem and on the eventual recovery and disposal of the plastic encountered at sea. Thanks to the collaboration with RawNews, all the search and recovery operations and the interviews are documented and finally presented to SeaPaCS volunteers and the whole community in the framework of the following project’s meetings, project that officially kicked off on the 1<sup>st</sup> of July, 2023 in the head office of the Italian Naval League in Anzio. The kickoff event has seen the participation of a broad audience of citizens, experts, and representatives of cultural, environmental and fishing associations.

Report:

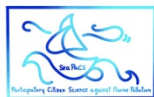
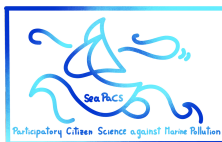

Cittadin\*–Scienziat\*  
contro la Plastica  
in Mare

# PESCANDO PLASTICA

11 luglio 2023

Peschereccio  
Paola Madre



The European Project SeaPaCS – Participatory Citizen Science against Marine Pollution – team jointly with Raw-News troupe, left the port of Anzio on the fishing boat MV Paola Madre on the 12<sup>th</sup> July 2023 to document the work at sea of the fishermen and interview them.

The MV Paola Madre is a 20m long fishing boat owned by Capt. Angelo Grillo. The crew is composed by Capt. Grillo and two fishermen from Egypt. During the night, three trawl catches were made in an area between 3 and 20 nautical miles from the coast. Every trawl was dragged for about 10 nautical miles for a duration of three to four hours each. The abundance of plastic was recorded for every catch, mainly fragmentary and mostly consisting of containers and plastic films. In this time of the year little trash was located and recovered due to little input from rivers for the lack of rains. The fishermen reported that, during the winter time, the trash recovered by the boats is about 70% more than the one recovered in summer time due to stronger marine currents and

rain events.

It is worth pointing out that the boat trip was made in an area of high trawling intensity, removing macroplastics too.

During the fishing activities, the SeaPaCS researcher interviewed Capt. Angelo Grillo and the crew members who confirmed that the presence of plastic and/or marine litter in general is significant and they can bring back to port at least a big bag of trash every two days. The fishermen reiterated that the typology of plastic fished is mainly composed of plastic bottles, but all the litter recovered and brought back must go to the general waste bin due to the lack of an “eco-centre” in Anzio where waste can be delivered according to its typology. Moreover, the fishermen reported that abandoned, lost or otherwise discarded fishing gears (ALDFG) including ropes can cause major problems to navigation as these intertwine with the propeller, while plastic films could clog the engine cooling system causing its overheating. These damages can cost the fishermen thousands of Euros, therefore plastic, they note, causes not only an environmental damage, but also an economic one.

In general, the fishermen stated that they are happy to recover plastic and marine litter to help to keep our seas clean, but they also point out that the presence of a garbage delivery system in the port would help, as well as little incentives could increase the participation in the waste collection at sea. The documentary material produced by the Raw-News team will be available in the coming months, we attach a preview of some photos taken during the work on board.

*Sampling Microplastics on a Sailing Vessel (<https://crowdusg.net/2023/07/08/sampling-microplastics-on-a-sailing-vessel/>)*

On Friday 14 and Saturday 15 July 2023, as part of the European project “SeaPaCS – Participatory Citizen Science against Marine Pollution”, citizens and representatives of local associations took samples of seawater to verify the presence of plastics and microplastics (plastic fragments of a size equal to or greater than 300µm) in collaboration with the project researchers,



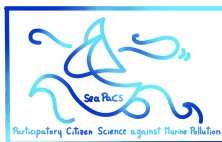

Luisa Galgani (GEOMAR Institute Kiel) and Chiara Certomà (University of Turin), with the logistical collaboration of the Italian Naval League of Anzio. The sampling, aimed at involving citizens in laboratory activities carried out in open and public spaces, took place over two days with the participation of about 30 citizens who expressed their interest in thoroughly understanding how marine research analyzes the problem of microplastics and what is the situation of the sea of Anzio and Nettuno. On the morning of 14 July 2023, the citizen scientists went to the small fishing port of Anzio to collect the plastic samples present in large quantities with self-made “baby-legs” nets. The collected samples were prepared in 5 tubes with a reagent that preserves the DNA even at room temperature making storage and transport in field analyses easier (DNA-RNA Shield by ZymoResearch). These samples will be sent to the

ZymoResearch laboratory for DNA extraction and sequencing with analysis for the purpose of studying the community of microorganisms living on the myco-plastic fragments found in the port of Anzio, divided by type (fibres, fragments, pellets of polystyrene) to understand if different materials can host different communities of microorganisms.

In conjunction with the performance of the SeaPaCS activity, on the morning of 15 July, the SeaPaCS team reached the local Legambiente Le Rondini club and the Costa Neroniana Rotary Club at the Salus plant in Nettuno for the “Let’s play recycling” initiative.

Our collaborator biologist Martina Gaglioti documented and produced a short video with the first results of the field-based work: [https://youtu.be/b9SotZIK\\_xw](https://youtu.be/b9SotZIK_xw).

In the afternoon of 14 July and on the day of 15 July, 3 excursions were carried out departing from the Italian Naval League of Anzio on a sailing boat with citizens to collect microplastic samples within 3 miles of the coast between Anzio and Nettuno through the use of a scientific instrument called NeustonNet capable of filtering seawater and storing the microplastics present in a special tank. The chosen monitoring technique required the adaptation of the NeustonNet towing system for totally experimental use on a sailboat, in order to make the entire research process more sustainable. The material brought ashore was released from the filter, classified and isolated in the appropriate test tubes to investigate the microbial community that has made marine plastic its habitat. 6 tubes were prepared for DNA analysis and plastic fragments analysis. Participating citizens have been explained in detail the functioning of the genetic analysis process, the progress of research on the subject and the ecological and social importance of tackling the problem.

The photographers and documentary filmmakers of the independent video-documentation company Raw-News fully documented the activities (available in the first months of autumn). Event page: <https://crowdusg.net/2023/07/08/sampling-microplastics-on-a-sailing-vessel/> SeaPaCS project website: <https://crowdusg.net/seapacs/>.



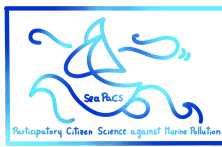

*Al-Jazeera's report to Anzio on the health of our seas (<https://crowdusg.net/2023/07/24/al-jazeeras-report-to-anzio-on-the-health-of-our-seas/>)*



The international channel of the Qatari broadcaster Al-Jazeera is documenting in Italy the historical increase in temperatures, not only atmospheric, but also marine. On Sunday 23 July 2023, the television report on marine pollution was broadcast in Anzio, in collaboration with the European project SeaPaCS – Cittadin\*-Scienziat\* against Plastic at Sea, with the Italian Naval League and with the Capo d'Anzio Diving Center.

The video is also available on their YouTube channel at the link <https://youtu.be/bLUkdQeA1DM>. In the short clip, the professional diver Davide Rinaldi of the Capo d'Anzio Diving Center dives with the Qatari crew in the waters in front of Anzio and recovers a large amount of plastic abandoned on the seabed; also, the television broadcaster, in collaboration with the SeaPaCS project, has released the first images shot by Raw-News during the sea-going trip with the fishermen (available at <https://crowdusg.net/2023/07/08/fishing-for-plastic/>) and finally interviewed the coordinator of the project Dr. Chiara Certomà, who once again reiterated how pollution (not only plastic) and rising temperatures threaten the health of our seas, especially the Mediterranean Sea.

*SeaPaCS among the bidding committee projects for the candidacy of Rome at World Expo 2030 (<https://crowdusg.net/2023/07/28/seapacs-among-the-bidding-committee-projects-for-the-candidacy-of-rome-at-world-expo-2030/>)*



The European project SeaPaCS – Participatory Citizen Science against Marine Pollution – has been included among the projects of the bidding committee for the candidacy of the city of Rome to Expo 2030.

The RUS (Network of Universities for Sustainable Development), to which the University of Turin belongs, supports the bidding committee for the candidacy for Expo 2023 and the implementation of an international dialogue in the meeting of 25 July 2023 at the FAO's headquarters in Rome on the topic "Healthy and Protected Oceans. For a Sustainable, Equal and Prosperous Future" on the occasion of the UN Food Systems Summit hosted by Italy this year. The work of the organizing committee and RUS led to the publication of a booklet entitled "Expo 2030 Rome for Healthy Oceans. A priority for SIDS and the entire world" (available for download at the bottom of this page) which deals with all the sustainability programs of Italian universities

participating in the RUS, including the Europe SeaPaCS project, coordinated by the University of Turin. Dr. Chiara Certomà (Department DIGGEO@ESOMAS, University of Turin), as coordinator of the SeaPaCS project, participated in the work held in Rome on 25 July at the FAO headquarters.

*SeaPaCS built its own LADI (Low-tech Aquatic Debris Instrument)*  
[\(https://crowdusg.net/2023/08/13/seapacs-built-its-own-ladi-low-tech-aquatic-debris-instrument/\)](https://crowdusg.net/2023/08/13/seapacs-built-its-own-ladi-low-tech-aquatic-debris-instrument/)



Within the framework of the European project SeaPaCS, the first prototype of the LADI trawl sampler (Low-tech Aquatic Debris Instrument) was built according to the guidelines of the CLEAR Project  
[\(https://civiclaboratory.nl/2016/06/29/ladi-trawl/\)](https://civiclaboratory.nl/2016/06/29/ladi-trawl/) and consequently adapted according to the materials and their availability in Italy.

LADI is an open-source DIY microplastics sampling net that, obviously, does not have the high costs of the Manta and Neuston Net scientific standard devices (the latter being the net we used during the sailing boat samplings in July – <https://crowdusg.net/2023/07/08/sampling-microplastics-on-a-sailing-vessel/> sailing sampling).

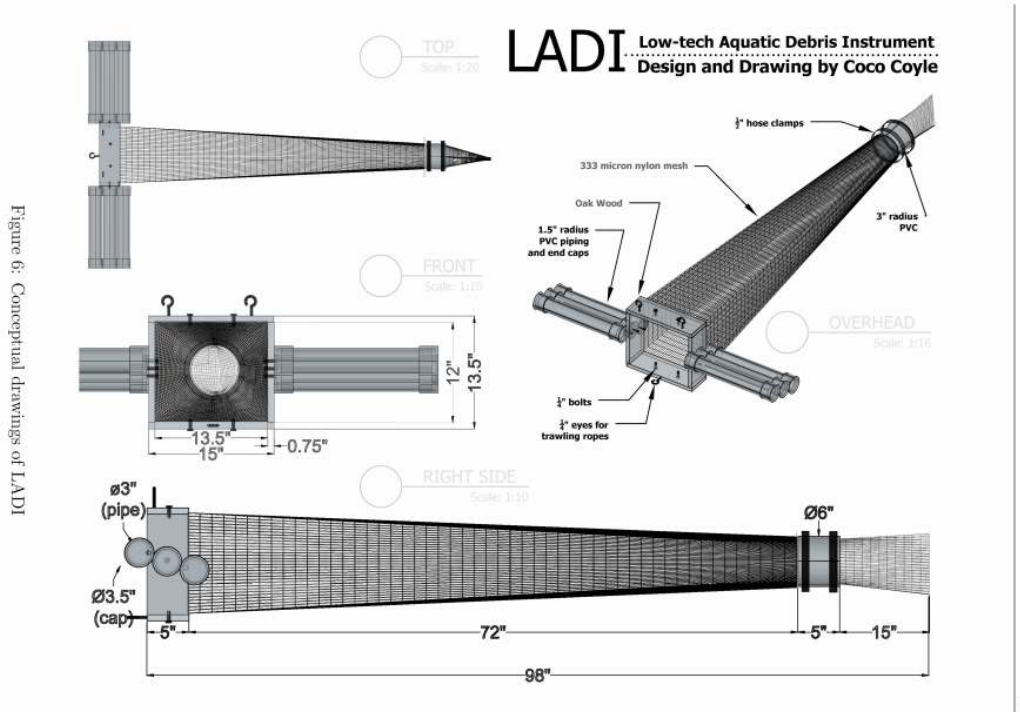

The Italian Naval League – Anzio Section, thanks to agreements already made with the “Rotary Club Costa Neroniana” and the UPA (“Union for the Environment”), we will use this

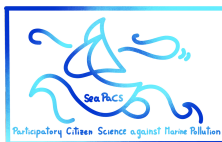

brand new LADI trawl, and another one soon-to-be built, for future projects in the territory of Anzio and as a follow-up of the current SeaPaCS project.

On the 14th of August, the SeaPaCS team tested the LADI in open water in a 20 minutes trawl and the experiment was fully successful.

*SeaPaCS and PreciousPlasticTorino: join the Lab!* (<https://crowdusg.net/2023/08/28/pp-lab/>)

The European Project SeaPaCS – Participatory Citizen Science against Marine Pollution, in collaboration with PreciousPlasticTorino, invites students and teachers from Anzio to the PRECIOUS PLASTIC Laboratory.

SeaPaCS proposes an interactive laboratory for schools in collaboration with the PreciousPlasticTorino fab-lab, a node of the Open Source Precious Plastic community.

During the workshop, students will be introduced to the problem of plastic in the sea, shown some examples and described the characteristics of the various types of plastic. Students will select the plastic coming from the sea which they will then recycle through shredding and extrusion using the self-built exercise bike and injector by PreciousPlasticTorino, recreating a new object from waste material.

The SeaPaCS project – “Participatory Citizen Science against Marine

Pollution” is supported by the European funds of the IMPETUS project with the aim of raising awareness of the consequences of marine plastic pollution on local biodiversity and triggering transformative actions oriented towards sustainability in the city of Anzio (Rome).

SeaPaCS is promoted by researchers from the DIGGEO@ESOMAS laboratory of the University of Turin – Italy and the Marine Biochemistry Division of the GEOMAR Helmholtz Center for Ocean Research Kiel – Germany, in collaboration with the Italian Naval League (LNI), section of Anzio.

The project combines biological and social research involving different groups of citizens (fishermen’s cooperatives, students, sports and environmental associations, sailors and divers and surfers, researchers, operators in the sector, videomakers, photographers and journalists) in collaboration with local bodies and institutions, in meetings open to all, training sessions and co-production of monitoring tools, dissemination of information material on the problem of marine pollution, collective maritime expeditions in coastal waters on sailing and fishing boats, interviews and organization of communication activities.

The Precious Plastic community was founded in 2013 by the Dutch designer Dave Hakkens, who builds a series of relatively simple machinery in design, partly using recycled and low-cost materials and non-specialized craftsmanship for small-scale plastic recycling.



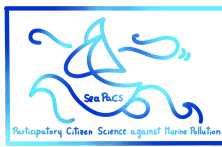

Subsequently, the technical schemes for the self-construction of these machines are networked and shared according to the principle of open sourcing, that is, the use open to all. Thus was born the PRECIOUS PLASTIC community, which currently has centers all over the world and continues to expand.

These centers are of various types, often private, sometimes linked to associations or cultural institutions, non-profit organizations, but also linked to universities and digital fabrication laboratories.

Ivan Martini, architect from Turin, in 2018, fell in love with this project and decided to open the PRECIOUSPLASTICTORINO hub: thus began a series of collaborations, linked to the university, associative, art, design world and also with realities that have an interest in the project to bring know-how to developing countries, where the theme of plastic is unfortunately very current and invasive.

The workshop will be held on October 27, 2023 from 9:30 to 12:30 at the Anzio headquarters of the Italian Naval League (Riviera Zanardelli 22, Anzio) and is totally free.

*SeaPaCS in London @ Royal Geographical Society Conference*  
(<https://crowdusg.net/2023/09/01/seapacs-in-london-rgs/>)



The team of the European Project SeaPaCS – Participatory Citizen Science against Marine Pollution, in particular its coordinator Chiara Certomà (DIGGEO@ESOMAS Lab., University of Turin) and Federico Fornaro (director of Raw-News media agency), presented the work of the SeaPaCS project with the screening of the video “In Search of Plastic”, shot and edited by Federico Fornaro and

Giuseppe Lupinacci, and the photographic exhibition “Explorations in the Plastisphere” with the vibrant underwater photographs by Giuseppe Lupinacci in London at the Annual International Conference of the Royal Geographical Society, Britain’s oldest and most internationally known institution for geographical and social research, in collaboration with the Imperial College (<https://www.rgs.org/research/annual-international-conference/>); the exhibition is set up in the Director’s Gallery (from 30<sup>th</sup> August 2023 until 10<sup>th</sup> September 2023, 1 Kensington Gore, London SW7 2AR).

The photographs of the exhibition were screened together with the video “In Search of Plastic” during the conference session 4 on Wednesday 30<sup>th</sup> August 2023 on the theme “Blue Hauntologies and Spectral Seas (conference program available at <https://www.rgs.org/research/annual-international-conference/programme/downloads-folder/ac2023-programme-book-programme-grid-7-august-2023.pdf/>).

The SeaPaCS team presents the work done on sea change in the Post-Anthropocene Epoch (title of the intervention: Staying with the problem in the Open Sea: On the plastisphere as hybrid ecological formation of the Chthlucene); in particular, the team is dealing with Visual Geography by reason of the collaboration with Raw-News media agency, trying to make



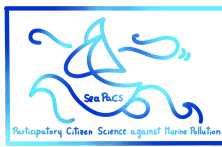

different languages dialogue, such as the visual language of images and videos together with the textual language of geographical theory.

Attached is the complete program and abstracts of the interventions of the session “Blue Hauntologies and Spectral Seas”.

### *SeaPaCS’s working groups*

After the first meeting (“collaboratorium”) held in Anzio on 1<sup>st</sup> July 2023, volunteers who joined our project have begun to participate in “working groups” which address various matters:

1. “Isola Ecologica” (Eco-Centre): this working group is a joint-collaboration between SeaPaCS and the municipal authorities of the city to address the problem of the lack of an Eco-Centre in the port of Anzio, as also emerged by the interviews to fishermen (see above, “Fishing for plastic” section). A first meeting with the municipal councillor for environmental policies was held on 31<sup>st</sup> July 2023. The municipal authorities are aware of the problem and, thanks to the citizens’ involvement, are intent to address it and solve it. After another meeting on operational and political issues about the Eco-Centre held on 4<sup>th</sup> September 2023, a survey of the port together with SeaPaCS’s coordinator and Anzio’s fishermen was carried out on 14<sup>th</sup> September 2023.
2. Sampling protocols: this working group is focused on drawing up a protocol for sampling plastics and microplastics by citizens-scientists. The protocol is designed to be carried out using the DIY LADI device and creates a common basis to analyse, observe and categorise plastic fragments sampled by them. A protocol about the construction of the LADI device has already been written.
3. Samples analysis: collected samples were sent to an external lab for DNA sequencing. FT-IR analysis of plastic samples is being processed.

### *Collaborations:*

- SeaPaCS has been [endorsed by the UN Ocean Decade programme](#)
- SeaPaCS has joined the [Community of Practice on Coastal Ecosystem and Community Resilience](#) managed by Decade Collaborative Center for Coastal Resilience – University of Bologna;
- SeaPaCS collaborates with [Trash Talk in Action](#)